

INTRODUCTION

The HotValley™ system holds self-regulating ice melt cable in place on roof valleys and flashings. It can be used in roof valleys (see above), on flashings next to vertical walls or on metal roofs. The supplied adhesive holds the HotValley in place.

In high snow load regions snow slides from adjacent roofs can overload the valleys and cause ice damming. The HotValley dissipates the heat of the ice melt cable over a wider area, therefore dramatically improving the size of the melt path.

The HotValley is available in Kynar 500 painted galvanized steel, Kynar 500 painted Aluminum, or copper. Special UL Listed 12 watt per foot self-regulating ice melt cable is provided with the system.

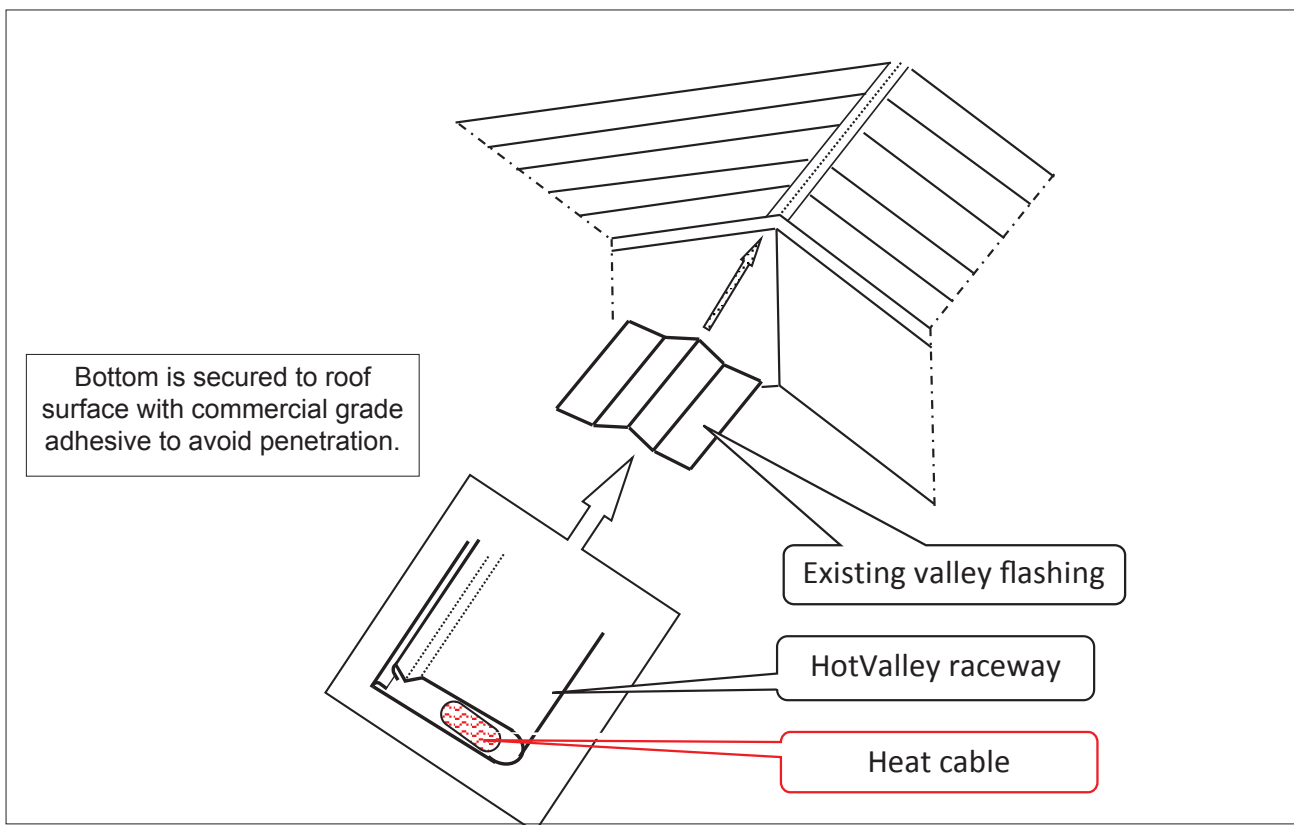

Overview

The overall objective is to keep the snow melt water in a liquid state until it is drained away from the structure's foundation. A heated gutter and downspout system is required for most applications.

Consult with a licensed electrical contractor for system layout, junction box placement, maximum cable run lengths and power feed requirements as defined by the National Electrical Code (NEC), local building codes and the ice melt cable manufacturer.

The ice melt cable manufacturer's installation instructions are provided with the cable. These procedures must be followed. Installation personnel must be skilled and be aware of the dangers inherent in this type of construction work. This product is designed to be part of a complete roof ice melt system. Only experienced professional contractors should install this product.

Completely read and understand these documents before starting the project.

HotValley™ Installation Instructions

Design & Planning the Installation

Ice melt cable splices are not permitted in the HotValley raceway. Individual home runs to an electrical junction box are highly recommended. The use of ice melt cable splices should be minimized as they can be problematic. Splices make troubleshooting and repair difficult and expensive. The expense of the extra footage of cable is an important investment.

Three extra feet of ice melt cable must be provided at each electrical junction box to allow the licensed electrical contractor to provide a drip loop and a power connection. At the end of the run, an extra one foot of cable is required for the installation of the end sealing device. If this extra cable is not provided, the entire run of ice melt cable will need to be replaced. Cable is easy to cut but it does not stretch!

Placement of HotValley

The HotValley raceways are attached to the existing metal flashings or asphalt composite shingles of the roof with the supplied system commercial grade adhesives.

Roof valley placements are important to provide heated drain paths where two roofs intersect. The HotValley raceways can also be installed on other flashings around chimneys and next to vertical walls to help maintain melt paths.

HotValley can be cut to length at the job site with hand held shears. It is important to dress the entry and exit points of the raceway to insure a smooth and dull edge surface. Any burrs or sharp edges can cut the protective plastic sheath of the ice melt cable and allow moisture to enter the cable.

Ice Melt Cable Insertion and Retention

The ice melt cable is inserted into the horizontal open slot along the length of the HotValley raceway.

It is important to avoid cutting or piercing the outer plastic sheath of the ice melt cable.

If water is allowed to leak into the cable it will cause slight ground fault condition that will trip the EPD ground fault circuit breaker that is required for all installations. Care should also be taken during the installation to insure the cut and open ends of the ice melt cable are not exposed to moisture. Moisture can be sucked into the cable through capillary action and make the cable unusable. Recommended practice is to wrap the ends of the cable with waterproof electrical tape to prevent water damage during installation.





The Roof Clip Bracket Kits are for use with 12-watt heat cables. The roof clips are used to secure 12-watt heat cables to roofs and gutters. Available from HotEdge, LLC.

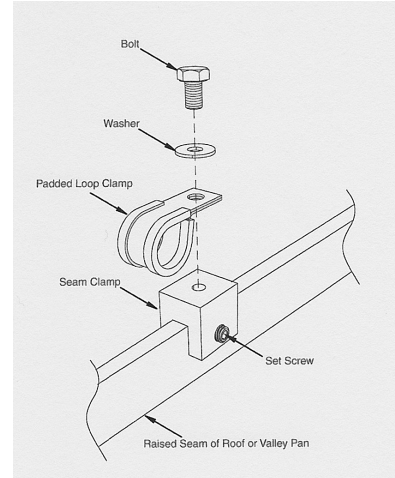

Custom seam clamp and padded cable loop available from HotEdge, LLC.

Retention of the Ice Melt Cable Run

Top retention is important so that the sliding ice and snow does not peel the ice melt cable away from the roof surface. All valley runs should be taken at least halfway up the roof valley if system layout allows you to terminate at the halfway point or to the ridge cap to prevent these issues. For up/down cable runs the cable loop at the top of the run needs to be secure. Top loop ice melt cable retention devices are available from Hot Edge, LLC

A 12 inch space is recommended between the top exit point from the HotValley and the retention device for the quarter twist of the cable as it enters the retention device. The bottom loop is normally run into the heated gutter to insure a completely heated drain path.

Electrical Connections

Only a licensed electrical contractor should power up the system. The electrical connections and end seals require an experienced contractor. Details of the electrical installation in this document are brief and do not cover the many variables encountered in the field. More information is available in the ice melt cable manufacturer's installation instructions provided with the ice melt cable.

EPD ground fault breakers with 30 ma trip points must be used, as per Article 426.28 of the NEC.

At low temperatures, the startup current of self-regulating ice melt cable can be quite large. Consult the ice melt cable manufacturer's maximum cable length data charts for additional information. The cold start up current load after a power failure should be considered in the design phase of the project.

In all cases, the UL Approved ice melt cable manufacturer's instructions over-ride the HotEdge® Installation Instructions.

WARNING

Low cost, constant current ice melt cable must not be used. Only safety agency "Listed", self regulating ice and snow heat trace cable for roof structures that are provided with the system can be used.

Consult with a licensed electrical contractor for system layout, junction box placement, maximum cable run lengths and power feed requirements as defined by the National Electrical Code (NEC), local building codes and the ice melt cable manufacturer.

Self-regulating Heating Cable Supplied with System

The HotEdge Rail is supplied with one of the following Listed (KOBQ) De-Icing and Snow-Melting Equipment Heating Cable and accessories (designed for roof and gutter de-icing and snow melt) indicated below and with the installation instructions provided by the heating cable manufacturer.

Products from NuHeat

NuHeat 13 Watt roof and gutter plug in cable 120V 5 ft	13PK08W1-5
NuHeat 13 Watt roof and gutter plug in cable 120V 10 ft	13PK08W1-10
NuHeat 13 Watt roof and gutter plug in cable 120V 15 ft	13PK08W1-15
NuHeat 13 Watt roof and gutter plug in cable 120V 25 ft	13PK08W1-25
NuHeat 13 Watt roof and gutter plug in cable 120V 50 ft	13PK08W1-50
NuHeat 13 Watt roof and gutter plug in cable 120V 75 ft	13PK08W1-75
NuHeat 13 Watt roof and gutter plug in cable 120V 100 ft	13PK08W1-100
NuHeat Heat Shrink Power Connection Kit (incl. 1 end seal)	RPPC
NuHeat Heat Shrink Splice.tee (incl. 2 End Seals)	RPST
NuHeat Heat shrink end seal (1pc)	RPES
NuHeat 13RGRC Roof Clips (box of 50)	RGRC
NuHeat Thermocube Thermostatic Outlet 120V	NH-THC
NuHeat Roof and Gutter Downspout hanger	RGDH
NuHeat Plug-in GFCI adaptor	FP-PLUG
120v NuHeat Roof & Gutter De-Icing Cable	13FP10W1
240v NuHeat Roof & Gutter De-Icing Cable	13FP10W2
120v NuHeat Roof & Gutter De-Icing Cable	R13P8-1
240v NuHeat Roof & Gutter De-Icing Cable	R13P8-2



Products from Tyco Thermal Controls LLC (Raychem)

- UL File KOBQ.E74811, De-icing and Snow-melting Equipment
- CSA Class 2872-01, File 021133_C_000 HEATERS-Cable and Cable Sets
- Raychem® IceStop® Roof & Gutter De-Icing Systems
- GM-1X Heating cables (120VAC, 10 watts per foot)
- GM-2X Heating cables (240VAC, 12 watts per foot and 277VAC, 12 watts per foot)
- FTC-P Power Connection & End Seal Kit
- FTC-HST Splice/Tee Connection Kit
- GMK-RC Roof Clips
- GM-RAKE Hanger Bracket
- Raychem® WinterGard Wet Roof & Gutter De-Icing Systems
- H612 Heating cables (120VAC, 6 watts per foot)
- H622 Heating cables (208-277VAC, 6 watts per foot)
- H900 Power Connection & End Seal Kit
- H910 Splice/Tee & End Seal Kit
- H913 & H914 Roof Clip Kits
- H915 Hanger Bracket Kit
- H908 120VAC Plug-in Power Connection Kit

System Test by the Electrical Contractor

Insulation Resistance (Megohmmeter) Test

The insulation resistance test is critical to ensure the safety and reliability of the heating cable system. This test should be performed as part of the installation of the system. It is also useful for troubleshooting an installed system. This test is required for warranty coverage from some cable manufacturers. See details in the ice melt cable manufacturer's installation instructions.

A large peak amp reading at cold start-up may indicate a current draw issue. Some systems may require time delay relays to spread out this peak load.

Individual home runs are recommended for troubleshooting, repair and replacement of the ice melt cable.