

HotSheet™ Panel – Design Guide
Order Entry Information & Engineering Specifications
Hot Edge, Inc. www.HotEdge.com

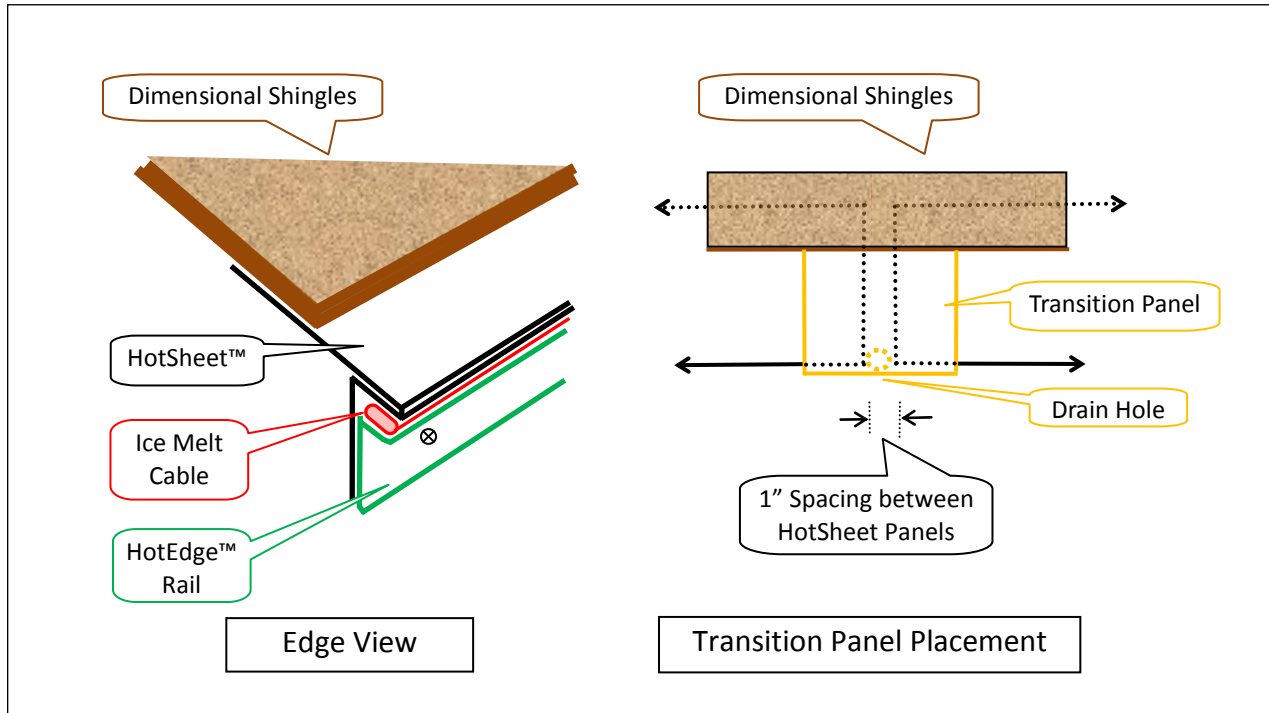

The HotSheet™ Panel – Part of the HotEdge™ Ice Melt System

The HotSheet™ Panels provide a metal drip edge for new construction or for roofs that have had the first row of the thick dimensional coverings removed. Once a metal drip edge is presented at the roof edge, the UL Listed HotEdge™ Rail and ice melt cable system can be installed. The idea of a metal slip sheet or snow slide at the roof edge has been used for a long time. The patent pending HotSheet™ and HotEdge™ Rail products make it easy to add a modern heated roof edge to many structures.

Note: In all cases, a one inch minimum metal drip edge must be present for the HotEdge™ Rail ice melt system to operate successfully.

Note: Specifications and tension guidelines are subject to change without notice. Before ordering material, insure the latest Revision Level of this document is used.

Warning: Low cost, constant current ice melt cable must not be used. Only safety agency Listed, self regulating ice and snow melt cable for structures that is provided with the system can be used.

HotSheet™ Panel and HotSheet™ Transition Panel Profiles

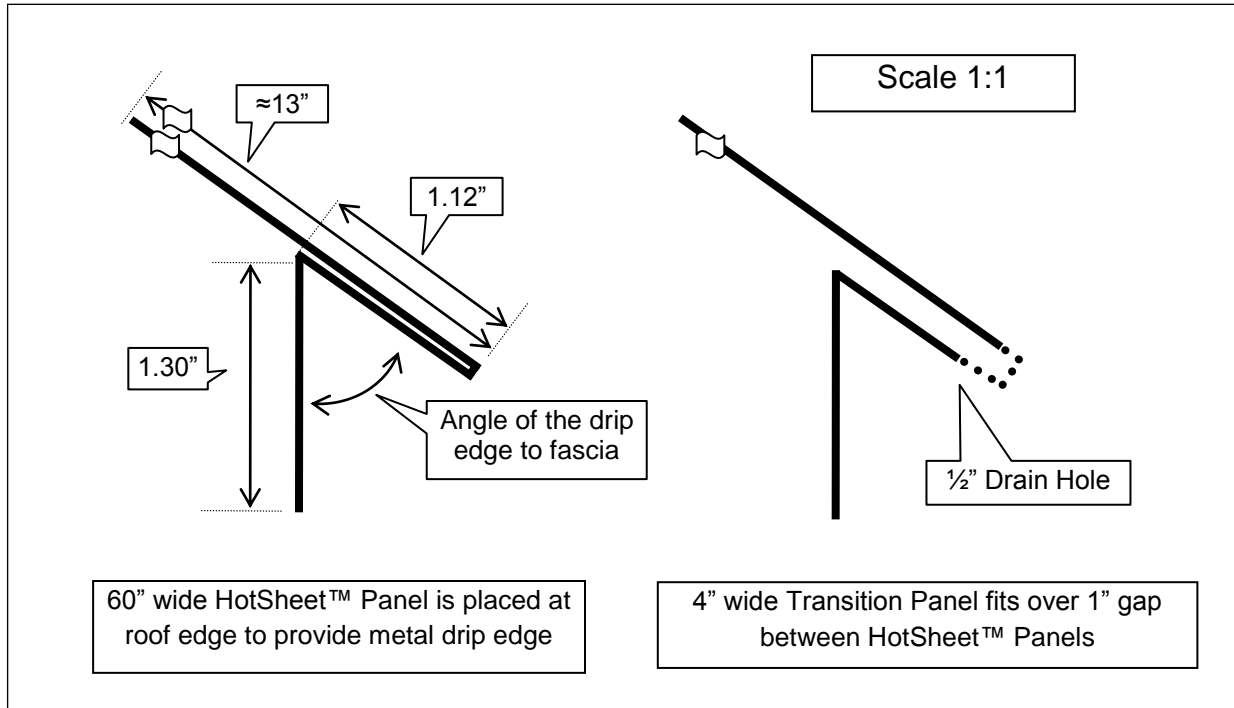

The HotSheet™ Panels are normally five feet wide and installed with a one inch gap for expansion and drainage between the panels. The four inch wide Transition Panel has a slightly larger inside cavity and fits over the gap between the longer HotSheet™ Panels. The ½ inch hole on the underside of the Transition Panel provides continuous drainage path for any water under the panel.

Overview

The overall objective is to keep the snow melt water in a liquid state until it is drained away from the structure's foundation. A heated gutter and downspout system is required for most applications.

It is necessary to create a spring-like holding tension to eliminate any air gap between the HotEdge™ Rail raceway, the ice melt cable and the bottom of the drip edge. The "storm window effect" of any air gap in this critical area dramatically decreases the amount of heat that is transferred from the self-regulating ice melt cable to the metal drip edge and metal fascia.

The UL Listed HotEdge™ Rail creates a three-sided raceway that holds a single run of self-regulating ice melt cable firmly against the bottom of the metal drip edge. This patent pending open raceway design conforms to the NEC (National Electrical Code) Article 426 and provides access for insertion, inspection and replacement. The heat generated by the ice melt cable is directly conducted to the metal drip edge. This helps prevent icicles and ice dams from forming in this critical area.

Angle Selection Guidelines

The angle of the HotSheet™ Panel should match the angle of the drip edge to fascia. This angle is sometimes different than the slope of the roof.

There are a number of variables, including the oil canning of the drip edge, the variation of the fascia and the flexibility of the different HotShingle™ Panel materials. For example copper is more flexible than steel, so a copper HotSheet™ Panel can span a slightly larger range than steel.

Every Roof is Different.

Some fascias are not vertical - they slope back toward the house. Some fascias may have been replaced and are not plum. On a given structure, several different angles may be encountered. Each drip edge to fascia angle should be measured carefully in degrees, not in roof pitch. Do not depend on the apparent roof pitch to be the actual angle of the drip edge to fascia when ordering product.

The various inside angles between the fascia and the bottom of the drip edge need to be determined to order the correct bend angle for the various Hot Edge Inc. products. It is recommended that a digital protractor be used for this task. The General Tools & Instruments Model 1702 is a suitable instrument. Available at Lowe's (www.lowes.com)

Roof Pitch Angle Chart		
Roof Pitch Ratio	Roof Pitch Angle	Plum Fascia to Drip Edge Angle
0:12	0°	90°
1:12	5°	85°
2:12	10°	80°
3:12	14°	76°
4:12	18°	72°
5:12	23°	67°
6:12	27°	63°
7:12	30°	60°
8:12	34°	56°
9:12	37°	53°
10:12	40°	50°
11:12	42°	48°
12:12	45°	45°

HotSheet™ Panel – Harmonized Part Number Nomenclature

HSHP 063 — S – HAGR — 060 — F13 — Rev11

<u>Hot Edge Inc. Products</u>	<u>Material & Color</u>	<u>Length</u>	<u>Options</u>																																																								
<table style="width: 100%; border-collapse: collapse;"> <thead> <tr> <th style="width: 50%;"><u>HotSheet™ Panel Angle</u></th> <th style="width: 50%;"><u>Roof Pitch</u></th> </tr> </thead> <tbody> <tr><td>HSHP 090 = HotSheet, 90°</td><td>(0:12)</td></tr> <tr><td>HSHP 085 = HotSheet, 85°</td><td>(1:12)</td></tr> <tr><td>HSHP 080 = HotSheet, 80°</td><td>(2:12)</td></tr> <tr><td>HSHP 076 = HotSheet, 76°</td><td>(3:12)</td></tr> <tr><td>HSHP 072 = HotSheet, 72°</td><td>(4:12)</td></tr> <tr><td>HSHP 067 = HotSheet, 67°</td><td>(5:12)</td></tr> <tr><td>HSHP 063 = HotSheet, 63°</td><td>(6:12)</td></tr> <tr><td>HSHP 060 = HotSheet, 60°</td><td>(7:12)</td></tr> <tr><td>HSHP 056 = HotSheet, 56°</td><td>(8:12)</td></tr> <tr><td>HSHP 053 = HotSheet, 53°</td><td>(9:12)</td></tr> <tr><td>HSHP 050 = HotSheet, 50°</td><td>(10:12)</td></tr> <tr><td>HSHP 048 = HotSheet, 48°</td><td>(11:12)</td></tr> <tr><td>HSHP 045 = HotSheet, 45°</td><td>(12:12)</td></tr> </tbody> </table> <table style="width: 100%; border-collapse: collapse;"> <thead> <tr> <th style="width: 50%;"><u>Transition Panel Angle</u></th> <th style="width: 50%;"><u>Roof Pitch</u></th> </tr> </thead> <tbody> <tr><td>HSHT 090 = T-Panel, 90°</td><td>(0:12)</td></tr> <tr><td>HSHT 085 = T-Panel, 85°</td><td>(1:12)</td></tr> <tr><td>HSHT 080 = T-Panel, 80°</td><td>(2:12)</td></tr> <tr><td>HSHT 076 = T-Panel, 76°</td><td>(3:12)</td></tr> <tr><td>HSHT 072 = T-Panel, 72°</td><td>(4:12)</td></tr> <tr><td>HSHT 067 = T-Panel, 67°</td><td>(5:12)</td></tr> <tr><td>HSHT 063 = T-Panel, 63°</td><td>(6:12)</td></tr> <tr><td>HSHT 060 = T-Panel, 60°</td><td>(7:12)</td></tr> <tr><td>HSHT 056 = T-Panel, 56°</td><td>(8:12)</td></tr> <tr><td>HSHT 053 = T-Panel, 53°</td><td>(8:12)</td></tr> <tr><td>HSHT 050 = T-Panel, 50°</td><td>(9:12)</td></tr> <tr><td>HSHT 048 = T-Panel, 48°</td><td>(10:12)</td></tr> <tr><td>HSHT 045 = T-Panel, 45°</td><td>(12:12)</td></tr> </tbody> </table>	<u>HotSheet™ Panel Angle</u>	<u>Roof Pitch</u>	HSHP 090 = HotSheet, 90°	(0:12)	HSHP 085 = HotSheet, 85°	(1:12)	HSHP 080 = HotSheet, 80°	(2:12)	HSHP 076 = HotSheet, 76°	(3:12)	HSHP 072 = HotSheet, 72°	(4:12)	HSHP 067 = HotSheet, 67°	(5:12)	HSHP 063 = HotSheet, 63°	(6:12)	HSHP 060 = HotSheet, 60°	(7:12)	HSHP 056 = HotSheet, 56°	(8:12)	HSHP 053 = HotSheet, 53°	(9:12)	HSHP 050 = HotSheet, 50°	(10:12)	HSHP 048 = HotSheet, 48°	(11:12)	HSHP 045 = HotSheet, 45°	(12:12)	<u>Transition Panel Angle</u>	<u>Roof Pitch</u>	HSHT 090 = T-Panel, 90°	(0:12)	HSHT 085 = T-Panel, 85°	(1:12)	HSHT 080 = T-Panel, 80°	(2:12)	HSHT 076 = T-Panel, 76°	(3:12)	HSHT 072 = T-Panel, 72°	(4:12)	HSHT 067 = T-Panel, 67°	(5:12)	HSHT 063 = T-Panel, 63°	(6:12)	HSHT 060 = T-Panel, 60°	(7:12)	HSHT 056 = T-Panel, 56°	(8:12)	HSHT 053 = T-Panel, 53°	(8:12)	HSHT 050 = T-Panel, 50°	(9:12)	HSHT 048 = T-Panel, 48°	(10:12)	HSHT 045 = T-Panel, 45°	(12:12)	<p>Material</p> <p>C= Copper, 0.021", 16oz., ½ Hard</p> <p>S= SMP Painted Galvanized Steel, 0.019"</p> <p>A = Kynar Painted Aluminum, 0.032"</p> <p>+</p> <p>Color</p> <p>NATC = Natural Copper (For copper material)</p> <p>ALMD= Almond CLRD = Colonial Red HMGR = Hemlock Green SLBL = Slate Blue BNWH = Bone White COPE = Copper Penny MNBN = Mansard Brown SLGR = Slate Gray MABL = Matte Black DKBZ = Dark Bronze MDBZ = Medium Bronze CLGR = Classic Green HAGR = Hartford Green SRTN = Sierra Tan</p>	<p>060= 60" (Note: 060 can be shipped UPS)</p> <p>004= 4" Transition Panel</p>	<p>F13 = 1.3" Fascia Height</p> <p>16 = 1.6" Fascia (Special Order – Will decrease total height)</p> <p>BTP= Build to Print (Special Order Only)</p>
<u>HotSheet™ Panel Angle</u>	<u>Roof Pitch</u>																																																										
HSHP 090 = HotSheet, 90°	(0:12)																																																										
HSHP 085 = HotSheet, 85°	(1:12)																																																										
HSHP 080 = HotSheet, 80°	(2:12)																																																										
HSHP 076 = HotSheet, 76°	(3:12)																																																										
HSHP 072 = HotSheet, 72°	(4:12)																																																										
HSHP 067 = HotSheet, 67°	(5:12)																																																										
HSHP 063 = HotSheet, 63°	(6:12)																																																										
HSHP 060 = HotSheet, 60°	(7:12)																																																										
HSHP 056 = HotSheet, 56°	(8:12)																																																										
HSHP 053 = HotSheet, 53°	(9:12)																																																										
HSHP 050 = HotSheet, 50°	(10:12)																																																										
HSHP 048 = HotSheet, 48°	(11:12)																																																										
HSHP 045 = HotSheet, 45°	(12:12)																																																										
<u>Transition Panel Angle</u>	<u>Roof Pitch</u>																																																										
HSHT 090 = T-Panel, 90°	(0:12)																																																										
HSHT 085 = T-Panel, 85°	(1:12)																																																										
HSHT 080 = T-Panel, 80°	(2:12)																																																										
HSHT 076 = T-Panel, 76°	(3:12)																																																										
HSHT 072 = T-Panel, 72°	(4:12)																																																										
HSHT 067 = T-Panel, 67°	(5:12)																																																										
HSHT 063 = T-Panel, 63°	(6:12)																																																										
HSHT 060 = T-Panel, 60°	(7:12)																																																										
HSHT 056 = T-Panel, 56°	(8:12)																																																										
HSHT 053 = T-Panel, 53°	(8:12)																																																										
HSHT 050 = T-Panel, 50°	(9:12)																																																										
HSHT 048 = T-Panel, 48°	(10:12)																																																										
HSHT 045 = T-Panel, 45°	(12:12)																																																										

The HotEdge™ Rail Roof Edge Ice Melt System

The UL Listed, HotEdge™ Rail roof edge ice melt System creates a three-sided raceway that holds a single run of self-regulating ice melt cable firmly against the bottom of the metal drip edge of most structures. This patent pending open raceway design conforms to the NEC (National Electrical Code) Article 426 and provides access for insertion, inspection and replacement of the ice melt cable. The heat generated by the ice melt cable is directly conducted to the top of metal drip edge. This helps prevent icicles and ice dams from forming in this critical area. The snow and ice melt water is not permitted to re-freeze at the drip edge and it can be safely drained away from the structure.

Some roofs will require the addition of a metal drip edge or a metal slip sheet (snow slide) that can be heated. Warning: In all cases, a metal drip edge must be present for the HotEdge Ice Melt System to operate safely and successfully. Hot Edge Inc. manufactures the HotSheet™ and the HotShingle™ products for this purpose.

Additional products are offered (e.g. HotValley and HotFlashing) to maintain a heated drain path for the ice melt water until it can be safely drained away from the foundation of the structure.

The ice melt cable manufacturer's installation instructions are provided with the cable. These procedures must be followed. Installation personnel must be skilled in the art and be aware of the dangers inherent in this type of construction work. This product is designed to be part of a complete roof structure. Only experienced professional contractors should install this product.

Consult with a licensed electrical contractor for the electrical system layout, junction box placement, maximum cable run lengths and power feed requirements with EDP breakers as defined by the National Electrical Code (NEC), local building codes and the ice melt cable manufacturer.

Completely read and understand these documents before starting the project.

Copyright © 2012 Hot Edge, Inc. All rights reserved.

No part of this publication may be reproduced, transmitted, transcribed, stored in a retrieval system, or translated into any language, in any form or by any means, electronic, mechanical, photocopying, recording, or otherwise, without prior written permission from Hot Edge, Inc.

All copyright, confidential information, patents, design rights and all other intellectual property rights of whatsoever nature contained herein are and shall remain the sole and exclusive property of Hot Edge, Inc. The information furnished herein is believed to be accurate and reliable. However, no responsibility is assumed by Hot Edge, Inc. for its use, or for any infringements of patents or other rights of third parties resulting from its use.

Hot Edge, Inc. hereby disclaims any liability for: user's failure to inspect, maintain, and take reasonable care of this equipment; injuries or damage resulting from use or application of this product contrary to instructions and specifications contained herein. Hot Edge, Inc.'s liability shall be limited to repair or replacement of equipment shown to be defective.